



World Leaders in Fluxgate Technology

**NMEA 0183 WINDSPEED AND DIRECTION
USER MANUAL FOR
A5120E
A5120N
A5120P**



A5120ENP manual 03.docx

Software releases:
V14

Hardware versions:
V2

**Autonnic Research Ltd
UK
www.autonnic.com**

Table of Contents

Introduction

- 1 General Information
 - 1.1 Wind direction
 - 1.2 Wind-speed
 - 1.3 Installation
 - 1.4 Maintenance
 - 1.5 Power Supply

- 2 Connecting to your application.
 - 2.1 To a NMEA-0183 instrument.
 - 2.2 To a PC serial port.

- 3 Digital Inputs and Outputs
 - 3.1 Outputs
 - 3.2 Inputs

- 4 References

Introduction

This manual describes the connection and operation of Autonnic's A5120 Wind Speed and Direction instrument. It is available in 3 variants:

A5120E extended tube length
A5120N normal tube length
A5120P short tube length intended for power boats or buildings.

In other respects the instruments are identical.

1 General Information

1.1 Wind Direction

The wind direction is sensed by the position of a small powerful permanent magnet fixed to the rotating vane. The fin of the vane is blown by the wind so as to be on the down-wind side of the A5120.

The A5120 contains a sensor which allows a microprocessor to acquire a binary value from two orthogonal sensors of the magnetic field from the vane magnet. The magnet is strong so that the effect of the Earth's field is small enough to be negligible. The processor calculates the vector from these values and then presents the data in a manner as a field in a serial data string. The processor can be requested to alter the frequency of the data, the degree of filtering and the offset value.

1.2 Wind-Speed

The anemometer part of the instrument contains two magnets - one to set the output of a sensor high and the other to set it low. By timing the period of the sensor output due to the rotation of the disc the microprocessor calculates the wind-speed.

1.3 Installation

The masthead unit should be mounted so as to position the A5120 so that its sensing parts, the cups and the vane, are always directly in the wind whatever direction it is coming from. In a boat the best place is high and forward of the mast. In fixed installations, the unit should be clear of a roof or similar obstructions, by at least half a meter.

Using the cable base as a template, spot mark through the fixing holes to the mast cap. The cable should run aft, with the single screw forward. Use stainless steel screws to fix the cap, (either No 6 self tapping screws, or M3 machine screws).

The A5120 can then be fitted to the base with the two screws provided. The unit is supplied with an IP67 pin connector. Various lengths of cable can be supplied with a mating socket connector. – see data sheet.

1.4 Maintenance

Although designed to give many years of life the head may be washed using warm water with detergent 1 drop to 200ml.

1.5 Power supply

The A5120 is compatible with any DC power supply of between 8 and 30 Vdc. Typical supply current during operation is approx. 15mA. The A5120 is not protected against reversed polarity.

2 Connecting the A5120 to your own system

2.1 To a NMEA-0183 instrument.

The hardware on which the NMEA-0183 standard is based on is a balanced serial protocol called RS422. This means that two wires are need for send and two for receive.

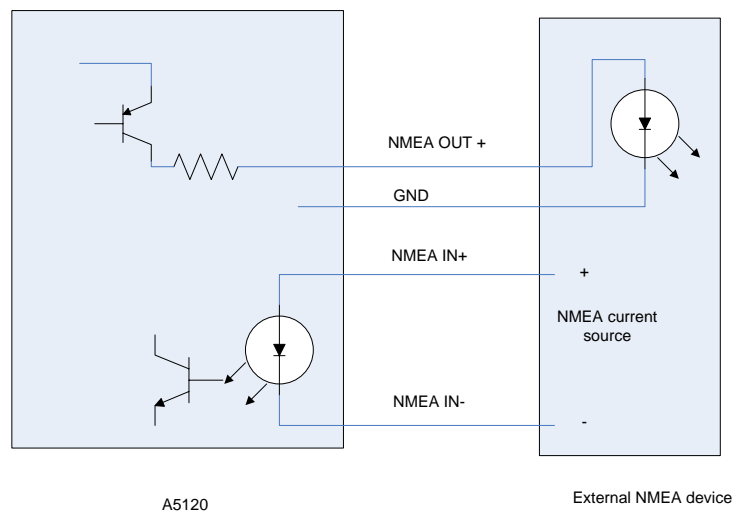

Fig 4

Note that the GND wire is used for the current return path. This might be shared with the NMEA- wire in some installations.

2.2 To a PC serial port.

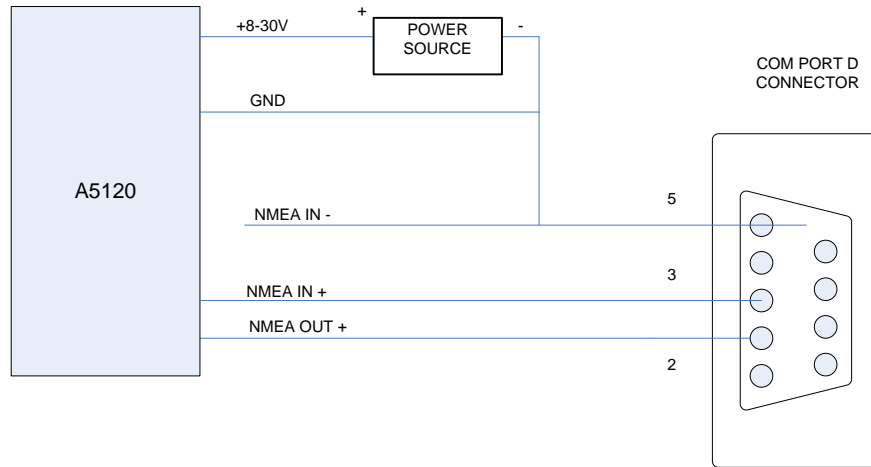

Fig 5

3 Inputs and Output available from the A5120

3.1 Outputs

Serial digital data sentences conform tot NEMA 0183 practice. The data rate is 4800b/s

The standard output sentence is of the form:

\$WIMWV,aaa.a,R,ss.s,N,A*hhhh<CR><LF>

where **a.a** is wind angle relative to the vessel's heading, 0 to 359.9 degrees.

s.s is wind speed

***hhhh** may be omitted or set to be a two digit checksum or the 5 digit serial number.

\$PATC,WIMWV,ACK<CR><LF>

When the sensor receives any of the input sentences listed below, it replies with the acknowledge sentence except mentioned special reply sentence.

But the fields in the sentence may be altered by the CONFIGURATION sentence – see below.

3.2 Inputs

\$PATC,IIMWV,CFG,x0<CR><LF>

Configure unit's output sentences' structure and reply with the standard acknowledge sentence.

If x=0, wind direction sentence will NOT include checksum nor unit's serial number.

If x=1, wind direction sentence will include checksum.

If x=2, send unit's serial number instead of checksum.

\$PATC,IIMWV,AHD,x.x<CR><LF>

Where **x.x** is the wanted reference angle, 0 to 359.9 degrees. Point the wind direction vane so that it is aligned with the forward axes of a vessel. Send this message with 0.0 as the reference direction angle. The output of the sensor will now show 0.0 degrees as the head wind direction.

\$PATC,IIMWV,DWD,x.x<CR><LF>

Where **x.x** is wind direction damping factor expressed as a percentage of from 0.0 to 100.0%. The value of 0.0 will give no damping and the value of 100% will give maximum damping.

Factory default value is 50%.

\$PATC,IIMWV,TXP,xxxx<CR><LF>

Where **xxxx** is the NMEA output repetition rate in milliseconds. The factory default is 500ms (0500) with a maximum value of 1.999s (1999).

\$PATC,IIMWV,RID<CR><LF>

This command causes the A5120 to respond with the special proprietary reply sentence

\$PATC,WIMWV,RID,hhhhh<CR><LF>

where hhhhh is the serial number in ASCII decimal.

\$SR

Responds with software release

\$SR_,A5120,xxx,yy,

Where xxx is version and yy is bootloader version

4 References

- 1 A5120ENP data sheet
- 2 NMEA-0183 specification

Autonnic and the *A logo and Fluxgateworld are registered Trade Marks of Autonnic Research Ltd
©2015

Autonnic Research Ltd Tollesbury Essex CM9 8SE UK